

# iSpindel PCB

assembly Instructions



2 pcb versions

2.1 → wrong TP4056 footprint, gnd losses

3.1 → corrected some bugs

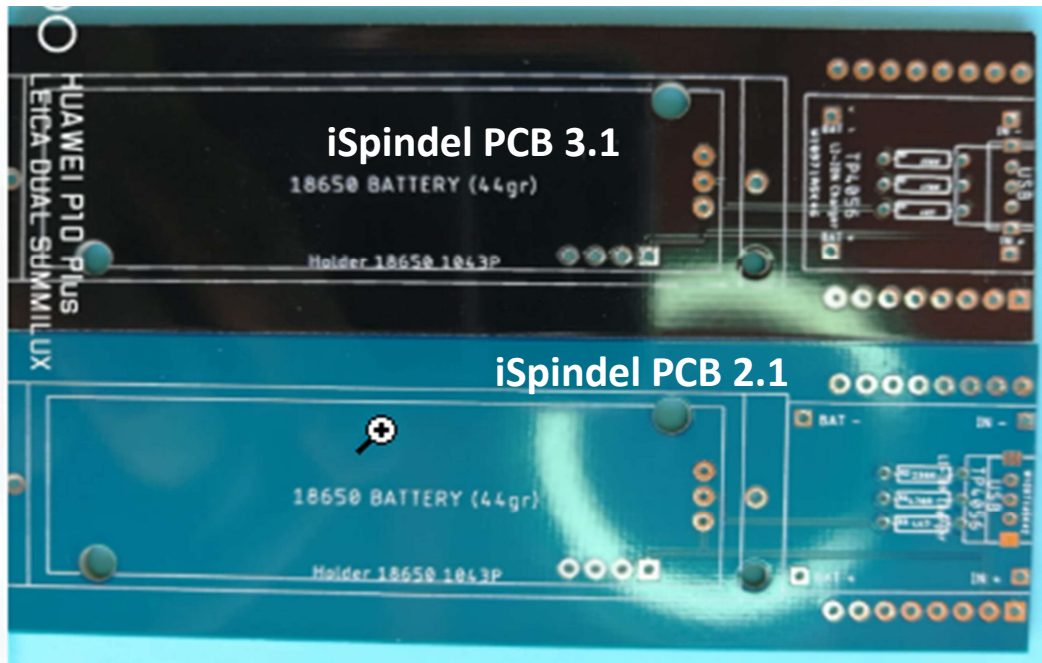

# Assembly steps: resistances

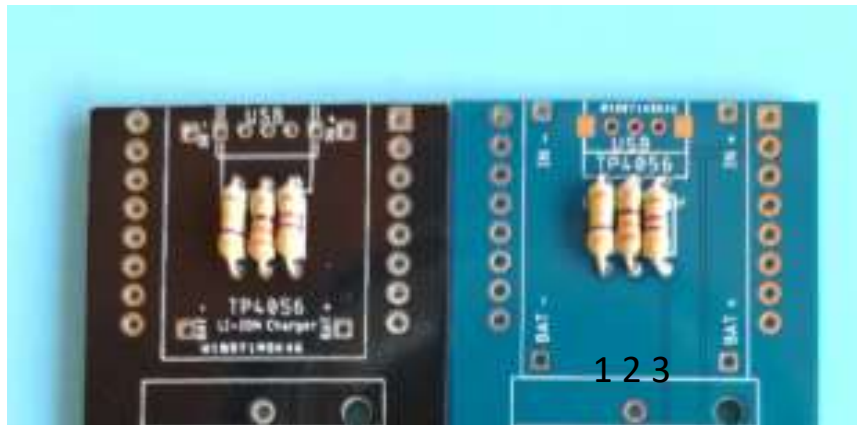

- 1) Assembling resistances places on battery holder side  
1 = 230K $\Omega$ ; 2 = 330 $\Omega$  or BAT43 diode; 3 = 4K7

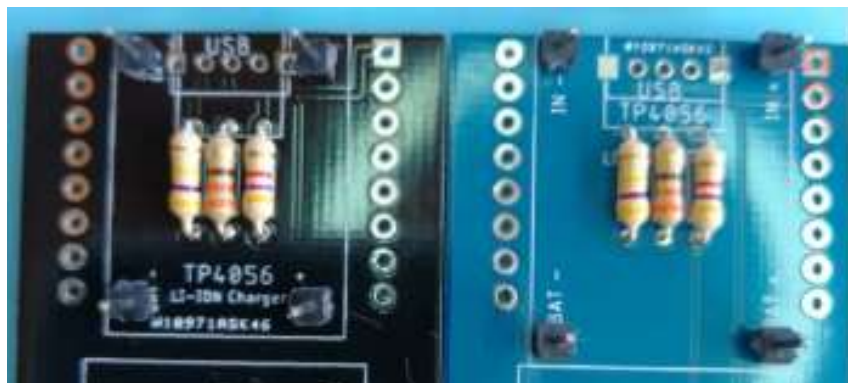

- 2) Mounting of 4 x pin header

- 3) Attention = only for 2.1 PCB version, wrong tp4056 footprint, it's need to adjust alignment between pin header and hole of tp4056 module.

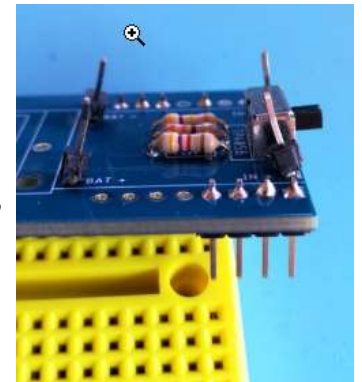

# Assembly steps: micro slide switch



- 1) Solder to slide switch  
Attention = only for 2.1 PCB version, please cut the pins of the external frame of the sliding switch



- 2) After mounting

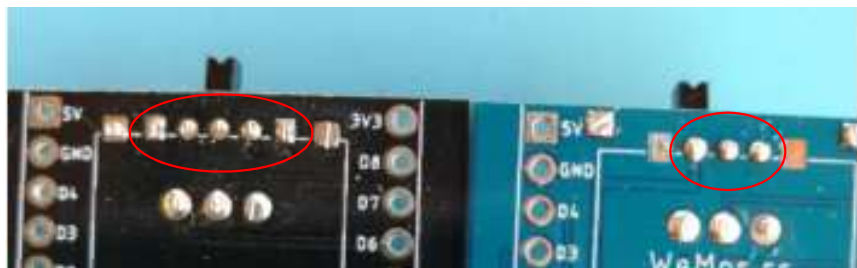

- 3) Please cut surplus pins to avoid possible short circuit with Wemos module

# Assembly steps: pin header (wemos)

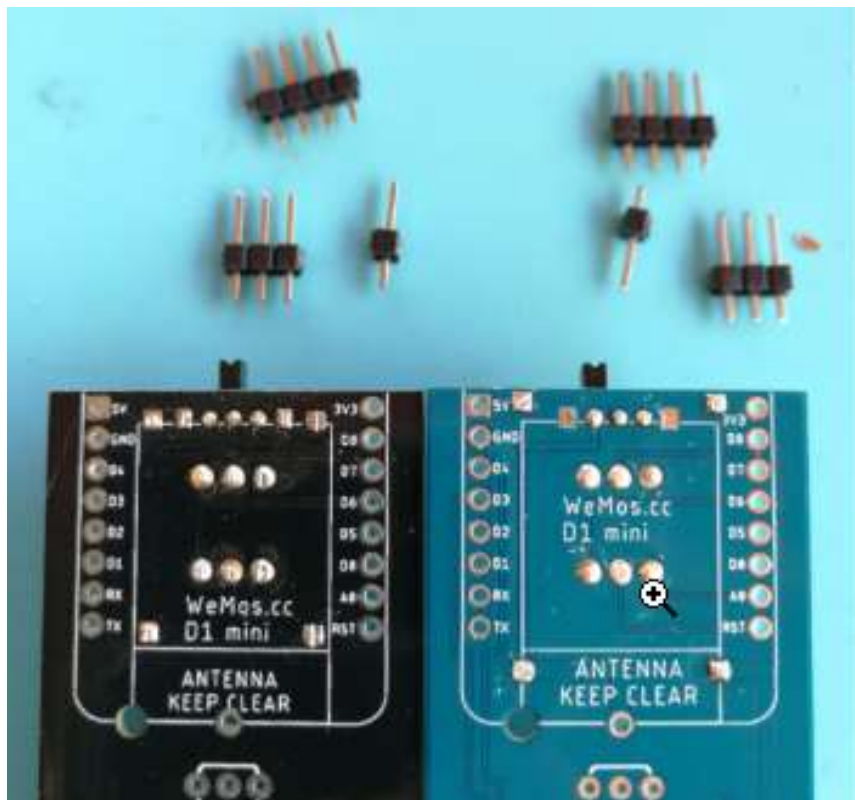

1) For mounting wemos module it's not necessary to weld all the pins, but only those interested. Prepare the pieces 1x4 pin, 1x1 pin , 1x3 pin as picture

2) Results after mounting

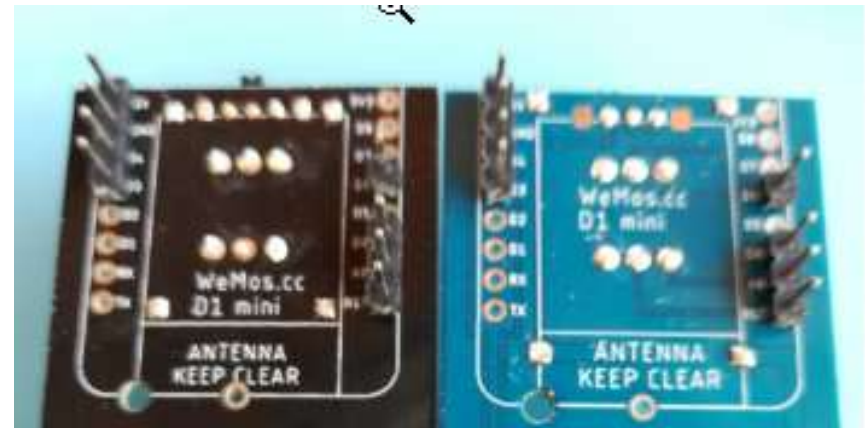



# Assembly steps: pin header (GY-521 – DS18B20)

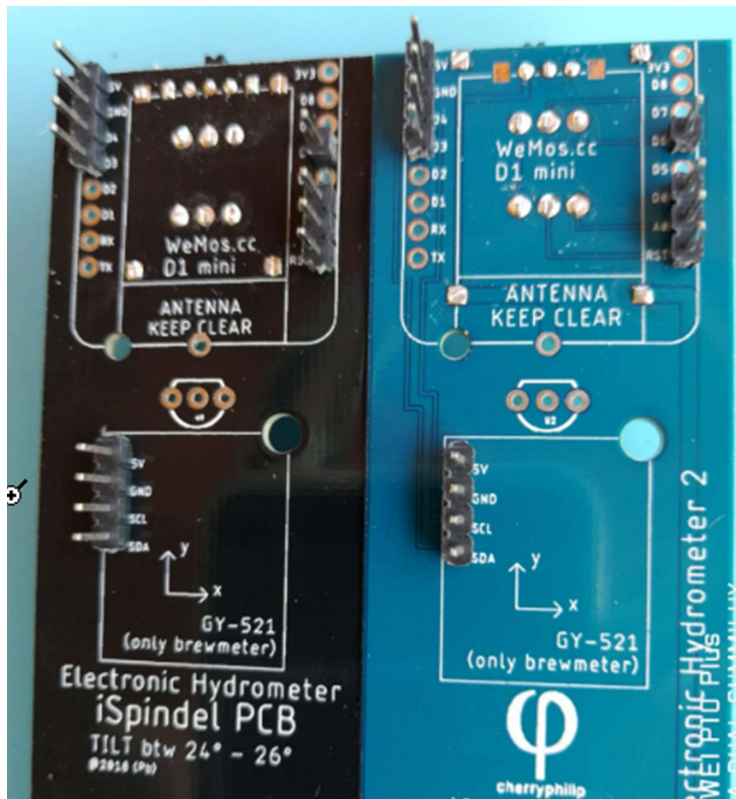

- 1) For mounting GY-521 module, please prepare the pieces 1x4 pin
- 2) Prepare dallas device , leave around 4mm pins over pcb
- 2) Results after mounting

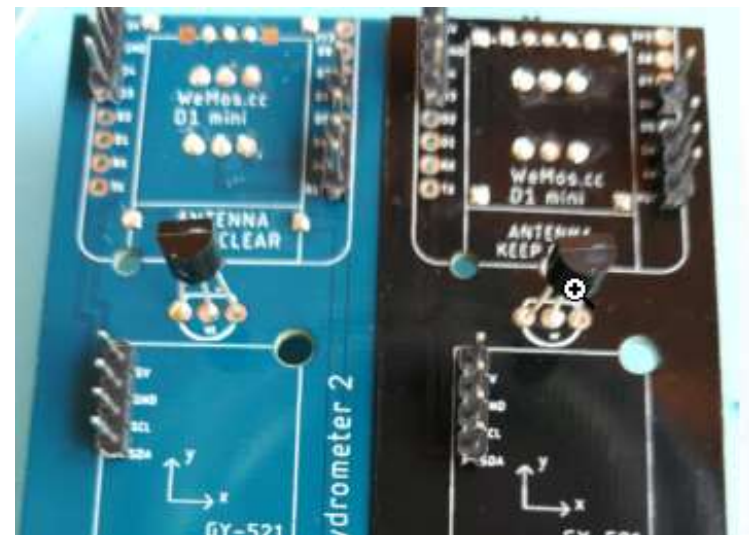

# Assembly steps: 1043 keystone battery holder TP4056 Lipo Module

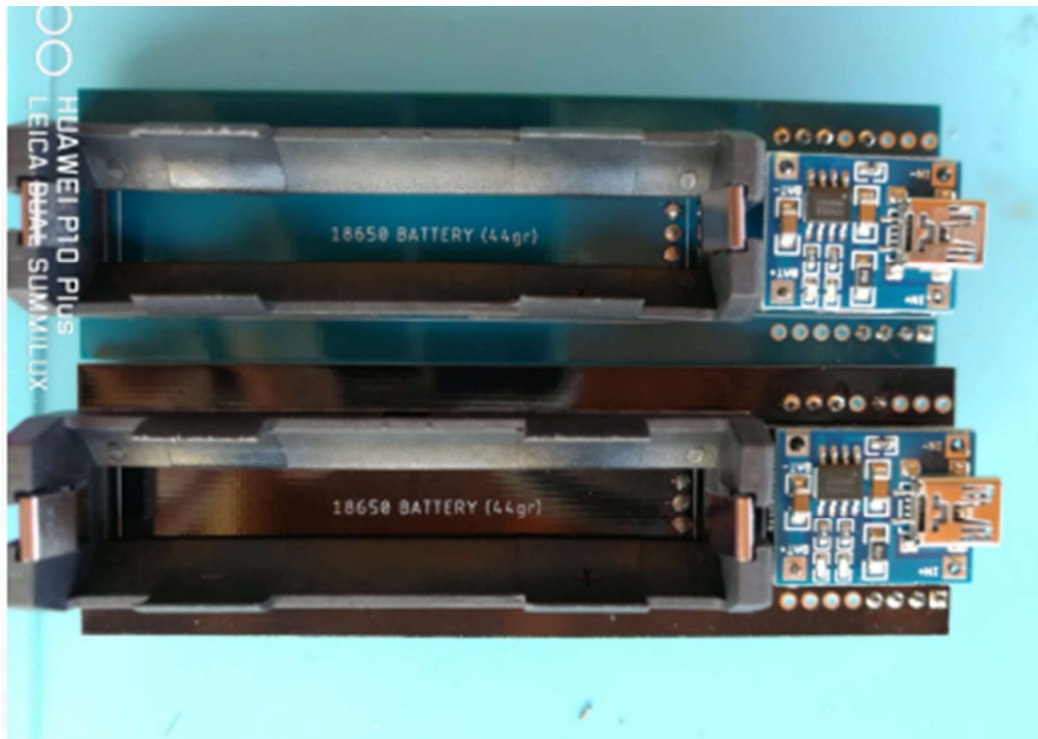

- 1) Rotate pcb on bottom side and places the battery holder before and tp4056 module after

# Assembly steps: GY-521 module



- 1) Use a female pin header as spacer, it's necessary when the gy 521 module must be welded. This way to ensure correct alignment with the horizontal plane.

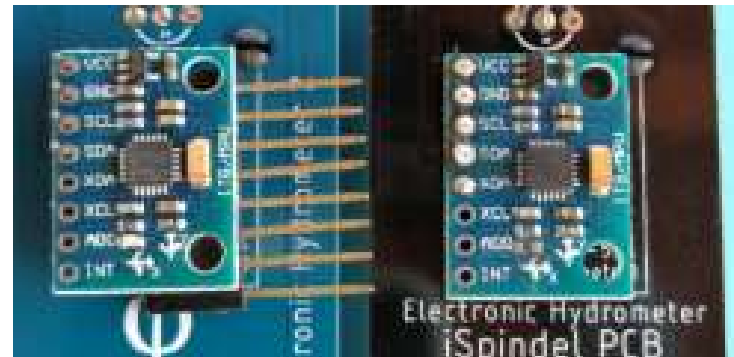



# Assembly steps: Check GND loss (only 2.1 version)

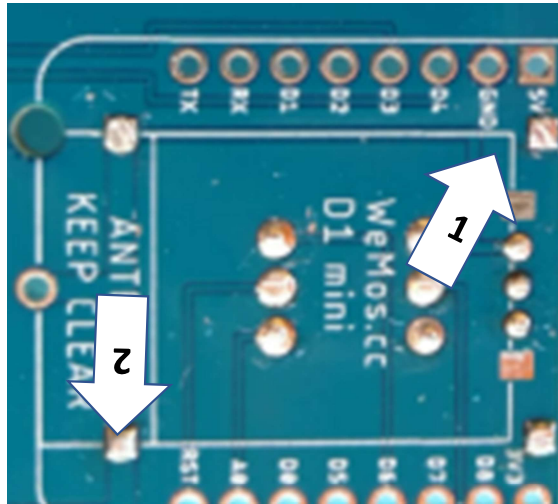

On some pcb (not all them) I found the ground plate loss

To check with multimeter the correct continuity between BAT- and GND (see points 1 and 2)

If it's OPEN, its must be remove a bit solder mask until to copper plate (see point 3) and to make a solder joint between BAT+ pin and copper plate (see point 4)

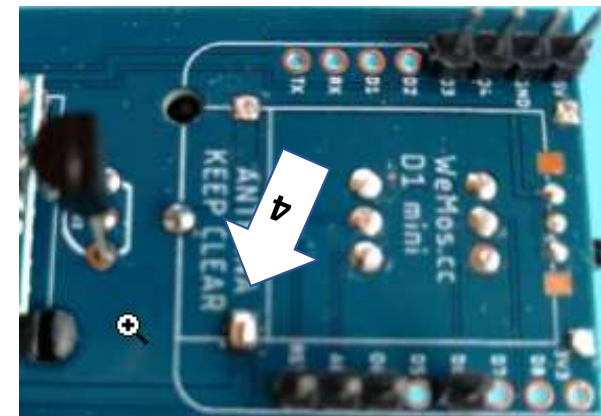
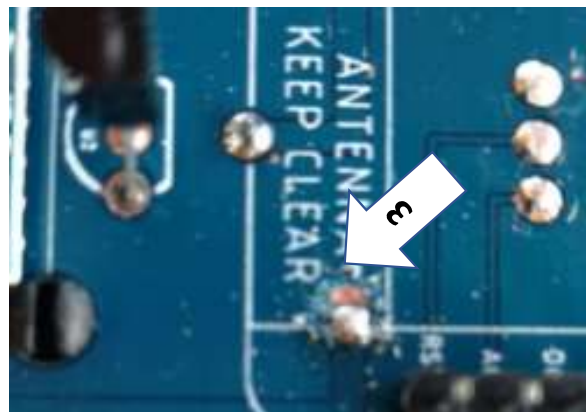

# Assembly steps: WEMOS module



- 1) Solder the wemos module.
- 2) My suggestion: install firmware before

# Assembly steps: Final assembly into PetLing



- 1) Insert to pcb into vial.
- 2) Ensure that the bottom base of the pcb touch the bottom of the vial (stop before the vial curvature and leave less 1cm)